

PLP® IBC Bracket

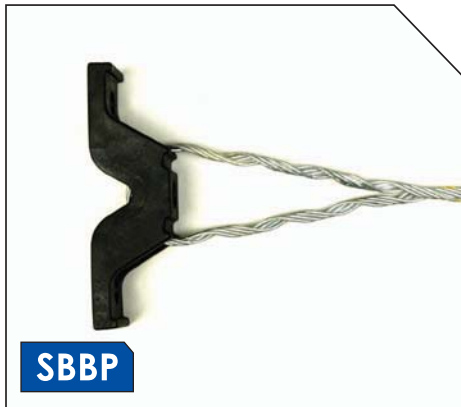

IBC Termination Assembly



SBBP

For Integral Bearer Cable/Figure 8 Cable

The PLP IBC Bracket is designed to support and terminate IBC communications cable, typically installed on distribution power poles.

Part Number	Bare Strand Diameter Range (mm)
SBBP-025	2.4 - 2.6
SBBP-038	3.6 - 3.8
SBBP-043	4.2 - 4.4
SBBP-048	4.7 - 4.9
SBBP-060	5.6 - 6.1

IBC Support Assembly

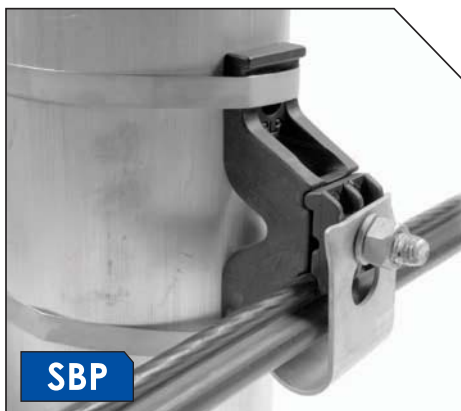

SBP

Part Number	Covered Strand Diameter Range (mm)
SBP - 01	5 - 8

PREFORMED™ Termination



For Figure 8 or Lashed Cable Applications



The PREFORMED™ Termination is a strand terminating device which is used by hundreds of electric power utilities, telephone companies, CATV companies and government installations throughout the world. PREFORMED™ Termination provide a superior, as well as economical way to secure guy by using a proven helical concept that provides a constant radial gripping force on the strand.

PREFORMED™ Terminations are made from the same basic material as the strand to reduce the possibility of electro-galvanic-corrosion.

Part Number	Strand Diameter Range (mm)
S424-00130-Blue	1/2.50mm
S424-00127-Green	7/1.25mm
S424-00128-Black	7/1.60mm
S424-00129-Yellow	7/2.00mm
GFG-060-LH*	7/2.00mm

- Material: Galvanised Steel.
- Lay: to suit right hand lay strand.
- * Lay: to suit left hand lay strand.

Fiberlign[®] Dielectric Suspension



Figure 8 Suspension Clamp



The Fiberlign Dielectric Suspension fitting is intended for use on (Figure 8) optical fiber cables, typically installed on distribution power poles. Cushion inserts gently grip the Figure 8 cable and provide moderate slip strength without damaging the cable jacket.

“Short Span” Series are recommended for Figure 8 spans up to 200m. Subject to Figure 8 cable design and operating conditions.

Line Angles:

Maximum recommended line angle for the Fiberlign Dielectric Suspension/Support Short Span Series is 20°. Greater angles can be achieved by using the Fiberlign Dielectric Suspension/Support Medium Span and Long Span Series.

Contact PLP for specific applications.

Figure 8 BPC (Bearer Pin Clamp)

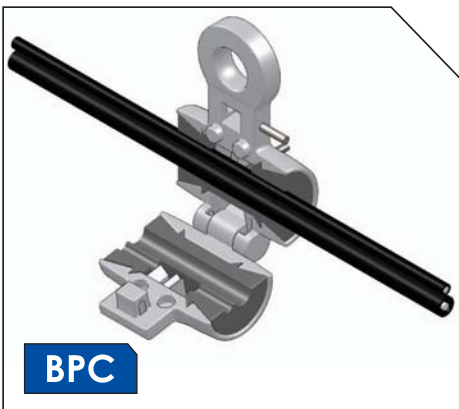

The Fiberlign BPC is design for short urban spans of figure 8 fibre optic cable. The clamp is manufactured from 30% glass filled nylon for superior strength and longevity. Neoprene inserts gently grip the figure 8 cable and provide adequate slip strength without compromising the cable jacket. Installation time is dramatically reduced with the clip/ pin design, requiring next to no tools for installation.

Line Angles:

Maximum recommended line angle for the BPC is 20° in total. Double suspension clamps can be used for greater turning angles.

Part Number	Figure 8 Fibre Count
BPC-072	72
BPC-144	144

Contact PLP for specific applications.

Fiberlign® Drop Wire Clamp



Drop Wire Clamp



DWC

The multi-purpose drop wire clamp is designed as an economical solution to securely terminate drop service cables. Made from aluminium or stainless steel the clamp can be used in all environments for a range of load conditions.

Part Number	Material	Cable Height (mm)	Cable Width (mm)
PUSU-DWC-44441	Aluminium	5.1 Max	10.4 Max
PUSU-DWC-88881	Stainless Steel	5.1 Max	10.4 Max
PUSU-DWC-82351	Aluminium	7.6 Max	12.7 Max

Drop Fibre Termination

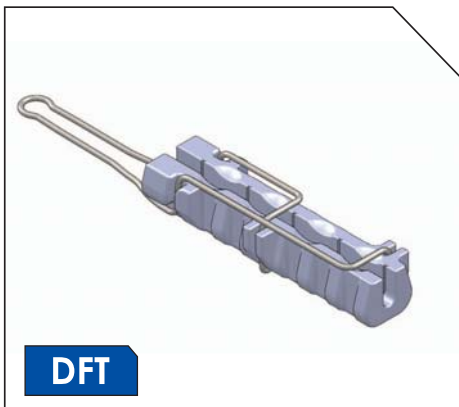

DFT

- Designed for fibre optic drop wires to the premise.
- Provides an economical design with reduced installation time.
- Cable is easily installed by pushing firmly into the keeper
- No tools required
- Constructed from glass filled nylon and stainless steel

Part Number

DFT-A

Contact PLP for specific applications.



PREFORMED LINE PRODUCTS
(THAILAND) LTD.

PREFORMED™ Strand Splice

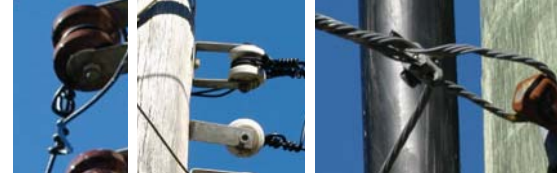

For SC/GZ



Preformed Strand Splices are used to repair strand or messenger cable simply and economically. Because of its superior design, the Preformed Strand Splice provides maximum strength and excellent fatigue characteristics, resulting in longer life for both strand and messenger.

Part Number	Strand Diameter (mm)
GFS-025	2.4 - 2.6
GFS-038	3.6 - 3.8
GFS-043	4.2 - 4.4
GFS-048	4.7 - 4.9
GFS-060	5.9 - 6.1
GFS-060-LH*	5.9 - 6.1

- Material: Galvanised Steel.
- Lay: to suit right hand lay strand.
- * Lay: to suit left hand lay strand.

PREFORMED™ Lashing Rod



Lashing Rod



Preformed Lashing Rods can be used on all types of messengered overhead cables. They are particularly adaptable to spans obstructed by trees, short spans over traffic intersections, or repairing existing installations. Once applied they provide a permanently snug and secure fit. The factory preformed helical rods have an overall low cost with simple installation that requires no special tools or lashing machines.

Part Number (Standard)	Part Number (Coated)	Conductor Diameter Range (mm)	Standard Pack Quantity	Colour Code
GLR-10-11	GLR-10-11C	10.00 - 11.00	100	Yellow
GLR-15-17	GLR-15-17C	15.00 - 17.00	100	Red
GLR-171190	GLR-171190C	17.10 - 19.00	200	Black
GLR-191213	GLR-191213C	19.10 - 21.30	200	Red
GLR-214239	GLR-214239C	21.40 - 23.90	200	White
GLR-240266	GLR-240266C	24.00 - 26.60	200	Orange
GLR-267297	GLR-267297C	26.70 - 29.70	200	Green
GLR-298332	GLR-298332C	29.80 - 33.20	200	Yellow
GLR-333371	GLR-333371C	33.30 - 37.10	200	Purple
GLR-372414	GLR-372414C	37.20 - 41.40	100	Red
GLR-415462	GLR-415462C	41.50 - 46.20	200	White
GLR-463518	GLR-463518C	46.30 - 51.80	100	Orange

Size Selection

In selecting the proper size lashing rod it is necessary to determine the smallest circumscribing circle that will enclose the messenger and cables.

For most installations, one Lashing Rod should be applied, overlapping one pitch length with each successive rod. Two Lashing Rods, applied 180° apart, are recommended when the cable-messenger assembly weighs more than 12 kg per metre, or at installation where the angle of sag exceeds 20° from the horizontal.

One Cable

For grouping only one cable with a messenger, add the diameters and multiply by a factor of 0.850

$$C = (D + m) \times 0.85$$

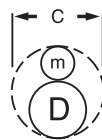

Two Cable

For grouping two equal diameter cables; multiply the diameter of one cable by a factor of 2.00. Then find the diameter of the maximum messenger that will fit in the interstices of the cables, and multiply the diameter of one cable by a factor of 0.666.

$$C = D \times 2.00$$

$$m = D \times 0.666$$



Three Cable

For grouping three equal diameter cables; multiply the diameter of one cable by a factor of 2.155. Then to find the diameter of the maximum messenger that will fit in the interstices of the cables, multiply the diameter of one cable by a factor of 0.483

$$C = D \times 2.155$$

$$m = D \times 0.483$$



Four Cable

For grouping four equal diameter cables; multiply the diameter of one cable by a factor of 2.414. Then to find the diameter of the maximum messenger that will fit in the interstices of the cables, multiply the diameter of one cable by a factor of 0.414

$$C = D \times 2.414$$

$$m = D \times 0.414$$



Unequal Diameter Cable

For grouping unequal diameter cables, or messengers too large to fit into the interstices above, the minimum diameter grouping can best be determined by a graphic layout to scale.